

\* REVISIONS

| LTR  | DESCRIPTION               | DATE       | REVISED | APPROVED |
|------|---------------------------|------------|---------|----------|
| △ X2 | 修改屏蔽片為4爪和4#腳加折邊扣住本體防屏蔽片脫落 | 2014.02.15 | ANDY    | JON      |
| △ X2 | 修HOUSING外觀與實物相符           | 2014.04.26 | ANDY    | JON      |

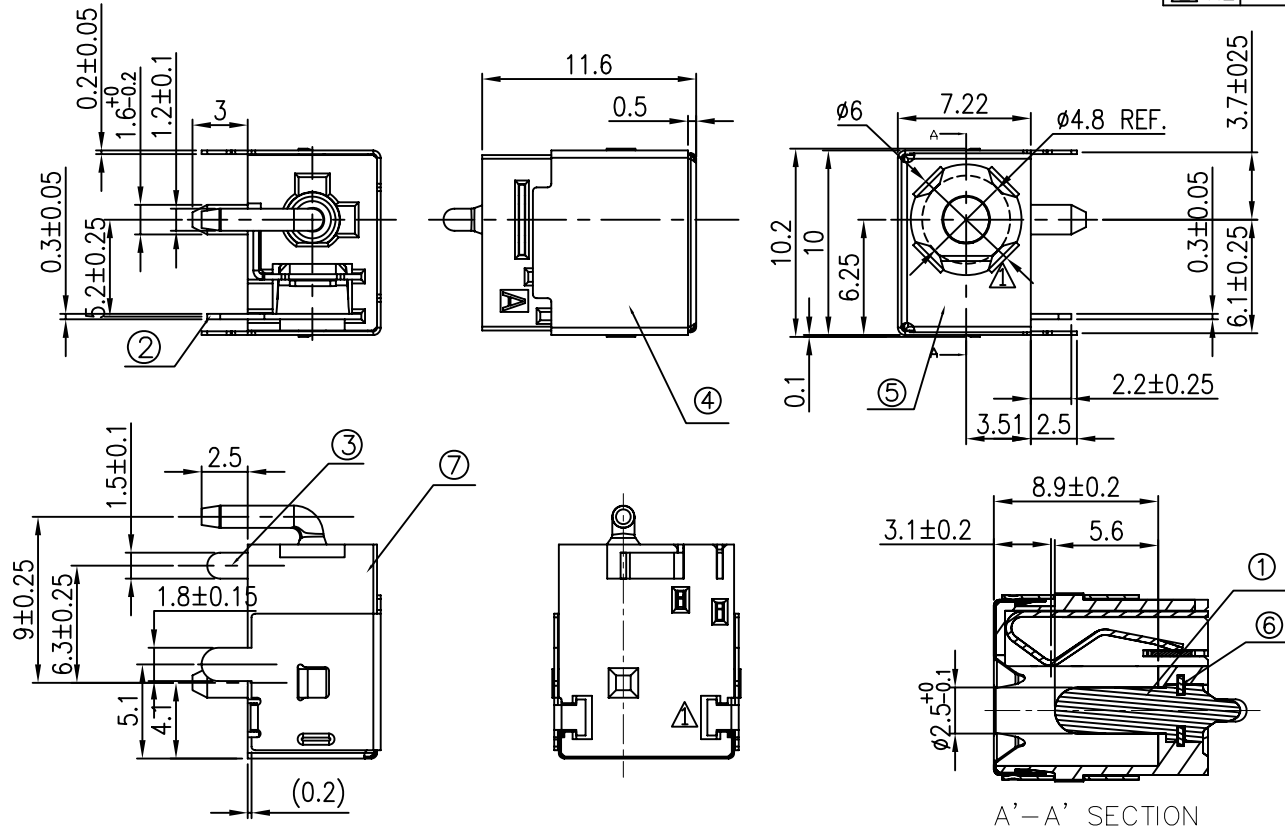

SPECIFICATIONS:

- ELECTRICAL CHARACTERISTICS:
  - RATING: 24V 5A
  - CONTACT RESISTANCE: 30mΩ MAX.(INITIAL)
  - DIELECTRIC WITHSTANDING VOLTAGE: 500V AC FOR ONE MINUTE
  - INSULATION RESISTANCE: 100MΩ MIN. MEASURED BY 500V DC
- MECHANICAL CHARACTERISTICS:
  - INSERTION FORCE : 0.3~3.0 KGF
  - WITHDRAWAL FORCE : 0.3~3.0 KGF
- LIFE TEST: 5,000 CYCLES MIN.
- FOR REFLOW SOLDERING LEAD-FREE PROCESS.

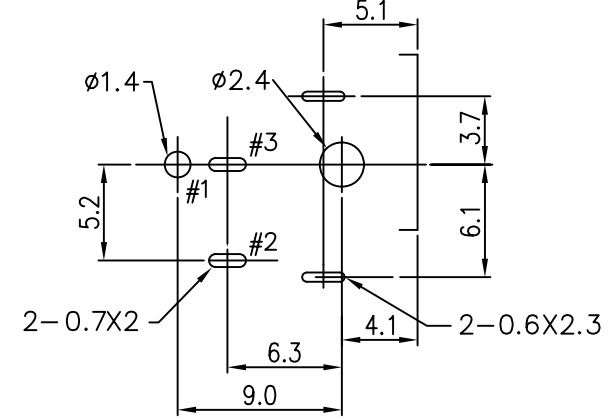

T:1.6 Dimensions of PC board holes

LEAD FREE Tolerance : ±0.05(Printed-top view)

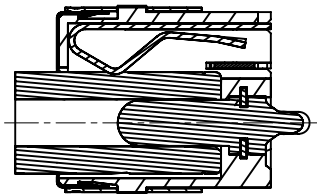

PLUG匹配示意?

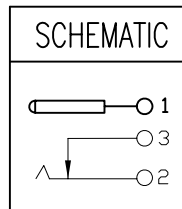

| 7                          | HOUSING          | 1    | PA9T               | UL-94V0(BLACK)   |
|----------------------------|------------------|------|--------------------|--|
| 6                          | TERMINAL         | 1    | SUS301 t=0.30±0.05 | N/A  |
| 5                          | GROUNDING SPRING | 1    | SUS301 t=0.10±0.05 | N/A  |
| 4                          | SHIELDING        | 1    | C2680 t=0.20±0.05  | Ni(50u"min) PLATED   |
| 3                          | CURVE PIECE      | 1    | C2680 t=0.30±0.05  | Sn(100u"min) PLATED  |
| 2                          | SPRING PIECE     | 1    | C5191 t=0.30±0.05  | Sn(100u"min) PLATED  |
| 1                          | PIN              | 1    | H59(COPPER ALLOY)  | Ni(50u"min) PLATED   |
| LTR                        | PART NAME        | QTY  | MATERIAL           | REMARK   |
| DWN                        | LILY             | DATE | 2014.02.15         | 3RD ANGLE PROJECTION<br>NAME DC POWER JACK<br>CAT. NO. DCD-020-108B<br>DWN.NO. A-020-108 002 |
| CHKD                       | ANDY             | DATE | 2014.02.15         |  |
| APVD                       | JON              | DATE | 2014.02.15         |  |
| UNIT: mm                   |                  |      |                    |  |
| JKCR Electronics Co., Ltd. |                  |      |                    |  |

UNLESS OTHERWISE SPECIFIED, TOLERANCE ON DECIMAL:±0.3