

\* RoHS COMPLIANT \*

\* REVISIONS

LTR	DESCRIPTION	DATE	REVISED	APPROVED

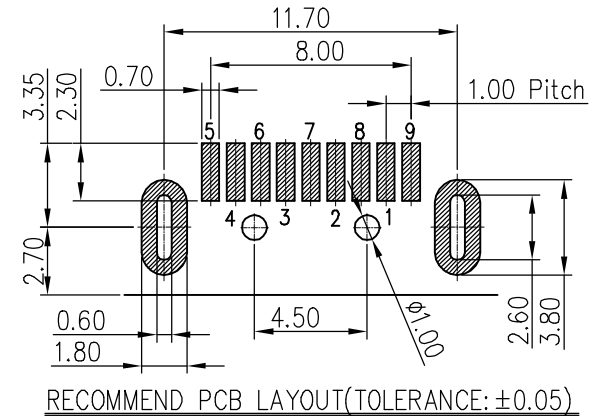
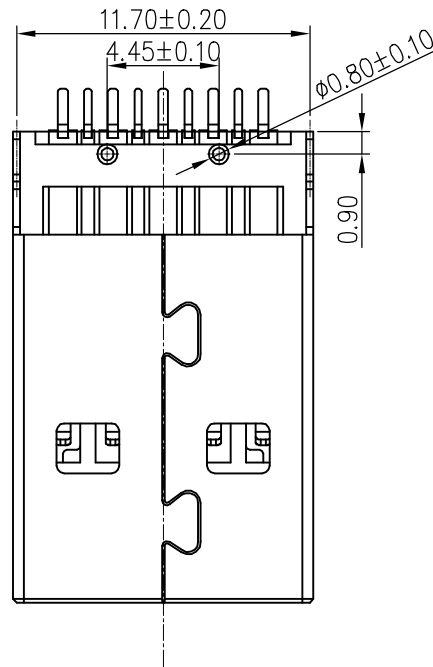
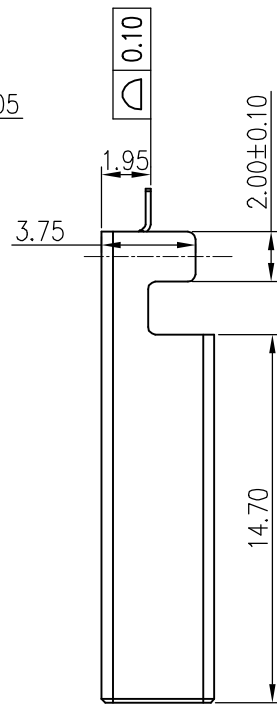
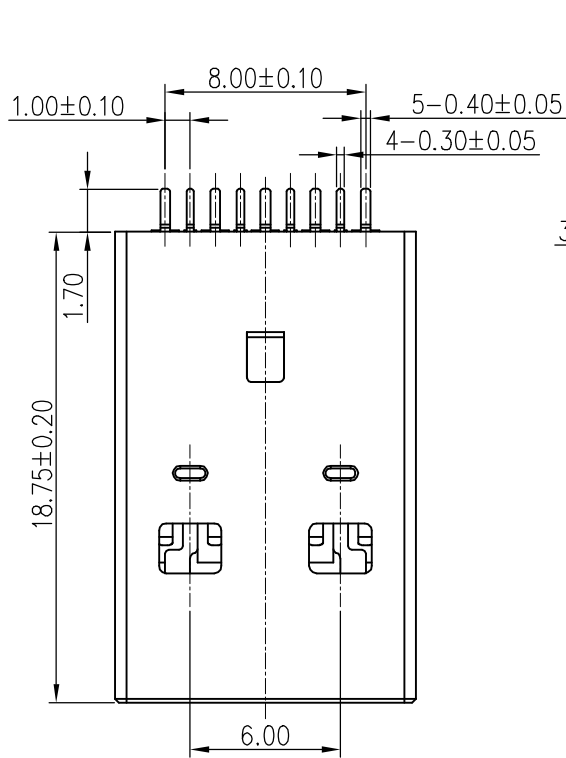

Notes:

1) Material:

Insulator : Thermoplastic G.F. UL94V-0,Bule  
 Contacts : Copper Alloy  
 Shell : SPCC

2) Environmental : -55°C to +105°C

3) Electrical

Voltage : 30VAC(R.M.S)  
 Current Rating : 1.5 Ampere Min.  
 Contact resistance : 30 Milliohms Max.  
 Insulation resistance : 100 Megohms Min.  
 Dielectric withstanding voltage : 500 VAC

4) Finish

Shell : 50u" min. Nickel  
 Contacts : 1~30u" min. Gold on mating area.  
 100u" min. Tin on the tails.

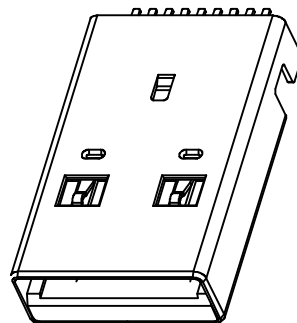
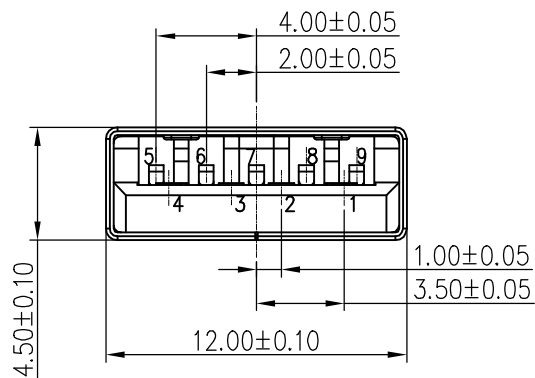

UNLESS OTHERWISE SPECIFIED, TOLERANCE ON DECIMAL: ±0.3

DWN	LILY	DATE	2023.10.06	3RD ANGLE PROJECTION	NAME	USB3.0 公座沉板1.9 18.7L 帶柱脚長1.7
CHKD	ANDY	DATE	2023.10.06		CAT. NO.	JCU3-104013472-A
APVD	JON	DATE	2023.10.06	UNIT: mm	DWN.NO.	JBL-104013472-A
JKCR Electronics Co., Ltd.						001