

\* RoHS COMPLIANT \*

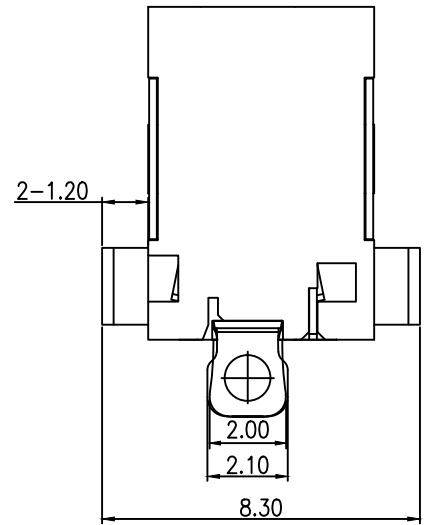
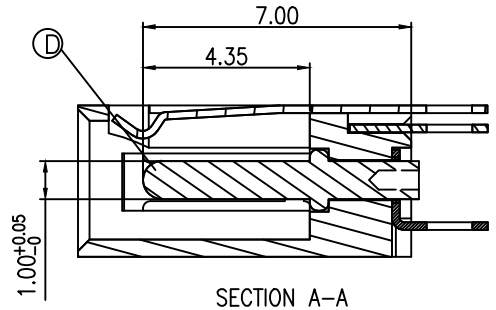
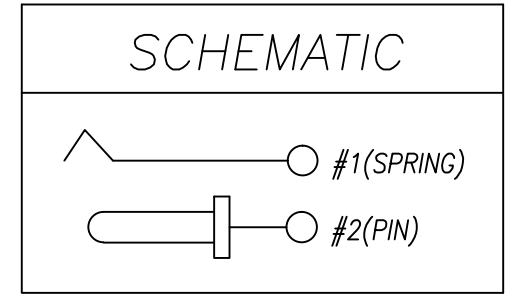
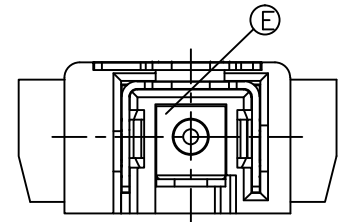
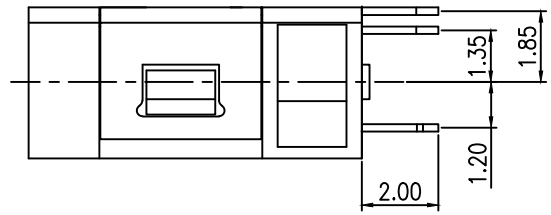
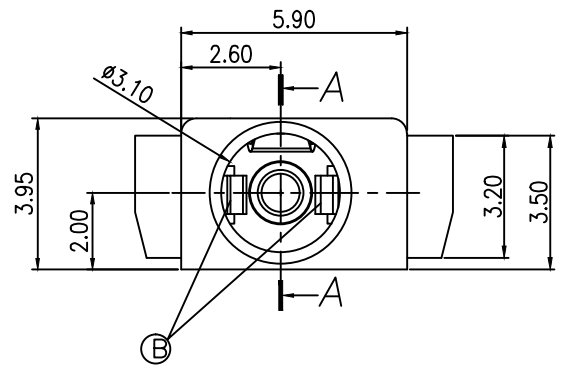
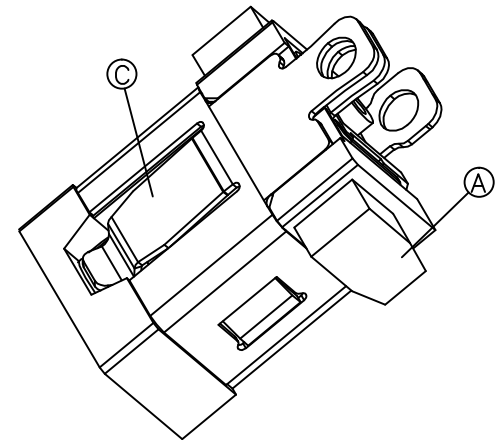
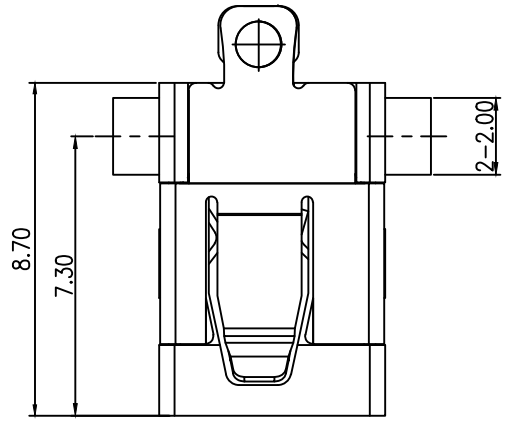

UNLESS OTHERWISE SPECIFIED, TOLERANCE ON DECIMAL: ±0.3

* REVISIONS				
LTR	DESCRIPTION	DATE	REVISED	APPROVED

SPECIFICATIONS:

1. ELECTRICAL CHARACTERISTICS:
  - 1-1. RATING: 12V 3A
  - 1-2. CONTACT RESISTANCE: 30mΩ MAX.(INITIAL)
  - 1-3. DIELECTRIC WITHSTANDING VOLTAGE: 500V AC FOR ONE MINUTE
  - 1-4. INSULATION RESISTANCE: 100MΩ MIN. MEASURED BY 500V DC
2. MECHANICAL CHARACTERISTICS:
  - 2-1. INSERTION FORCE : 30N MAX.
  - 2-2. WITHDRAWAL FORCE : 9N MIN.
3. LIFE TEST: 10,000 CYCLES MIN.
  - 3-1. INSERTION FORCE : 30N MAX.
  - 3-2. WITHDRAWAL FORCE : 8N MIN.
4. FOR REFLOW SOLDERING LEAD-FREE PROCESS.

E	TERMINAL	1	C5191	Sn PLATED
D	PIN	1	H59	Ag PLATED
C	SHELL	1	C5191	Ag PLATED
B	SPRING	1	C5191	Ag PLATED
A	BODY	1	PA9T	BLACK
LTR	PART NAME	QTY	MATERIAL	REMARK
DWN	LILY	DATE	2018.08.08	3RD ANGLE PROJECTION NAME DC POWER JACK CAT. NO. DCD-020-113A DWN.NO. A-020-113 001
CHKD	ANDY	DATE	2018.08.08	
APVD	JON	DATE	2018.08.08	
JKCR Electronics Co., Ltd.				